

PRINTING INSTRUCTIONS

Print at full-scale and place tools over the paper to verify the fit.

Option 1: Print this page full-scale on a large-format printer (E-Size, 44 inches X 34 inches).

Option 2: Print page 2 - 5 on 8-1/2 X 11 inch paper and assemble.

THE INFORMATION CONTAINED ON THIS DRAWING IS THE SOLE PROPERTY OF FOAMFIT TOOLS AND MAY NOT BE USED WITHOUT PERMISSION. Copyright 2026 FoamFit Tools

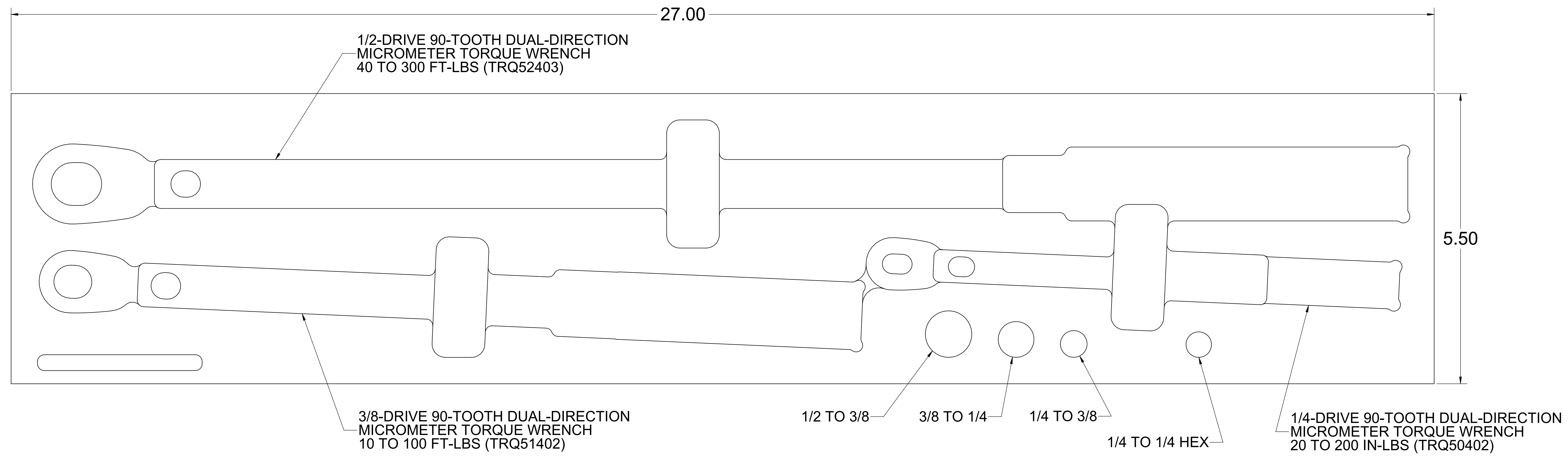
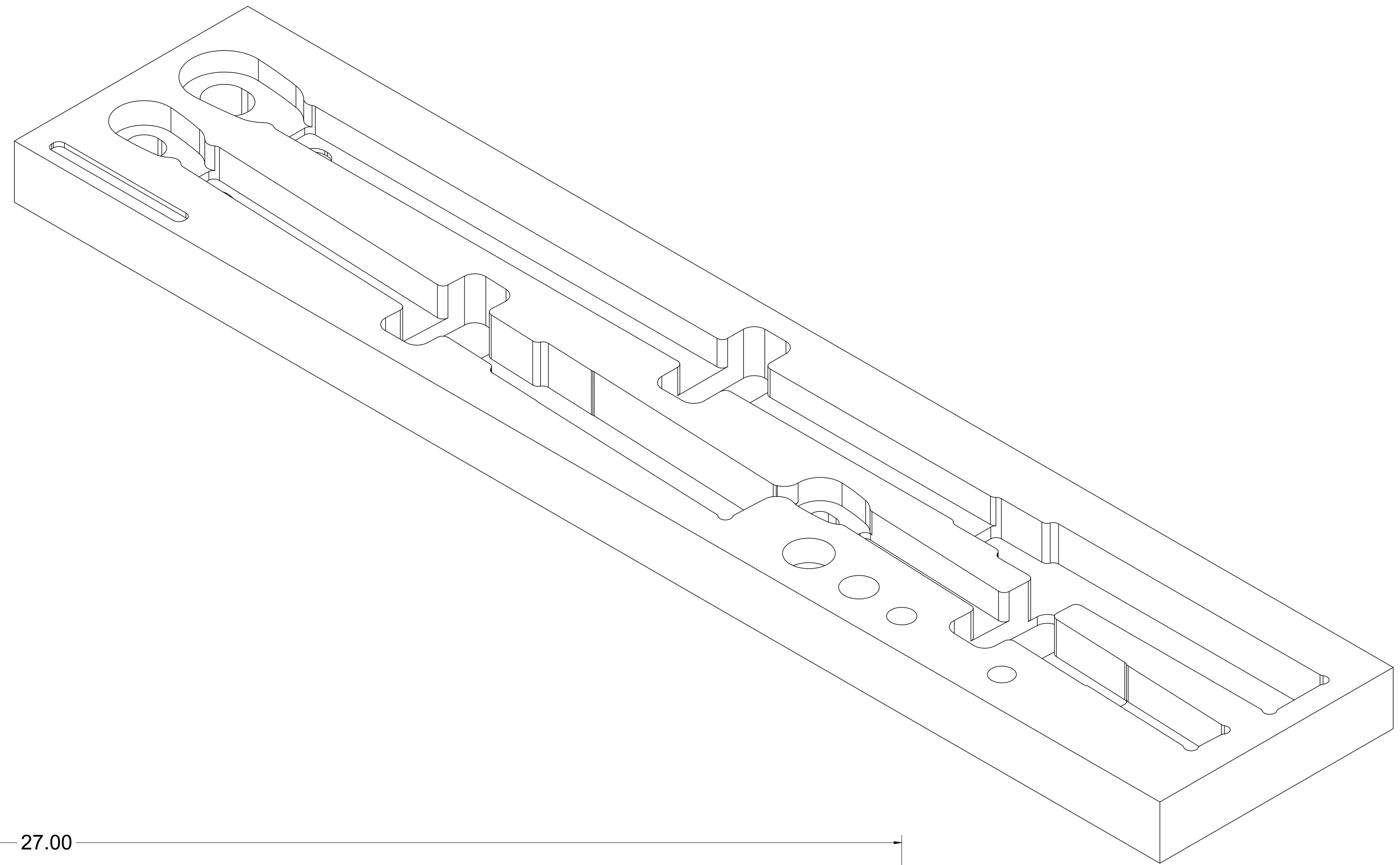

CAUTION
SUGGESTED DRAWER HEIGHT
2.44 MIN

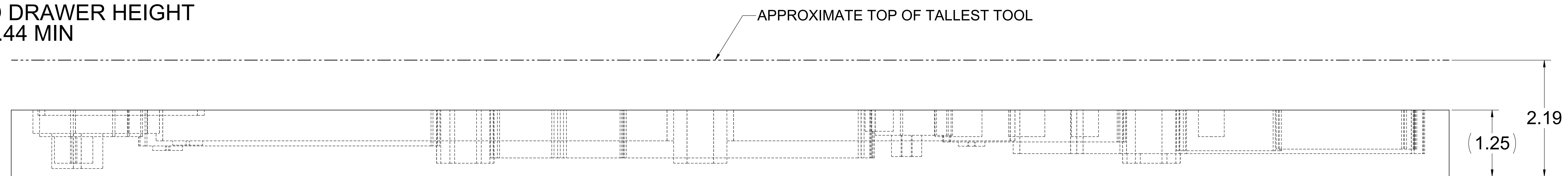

PART NUMBER
F-06427-T

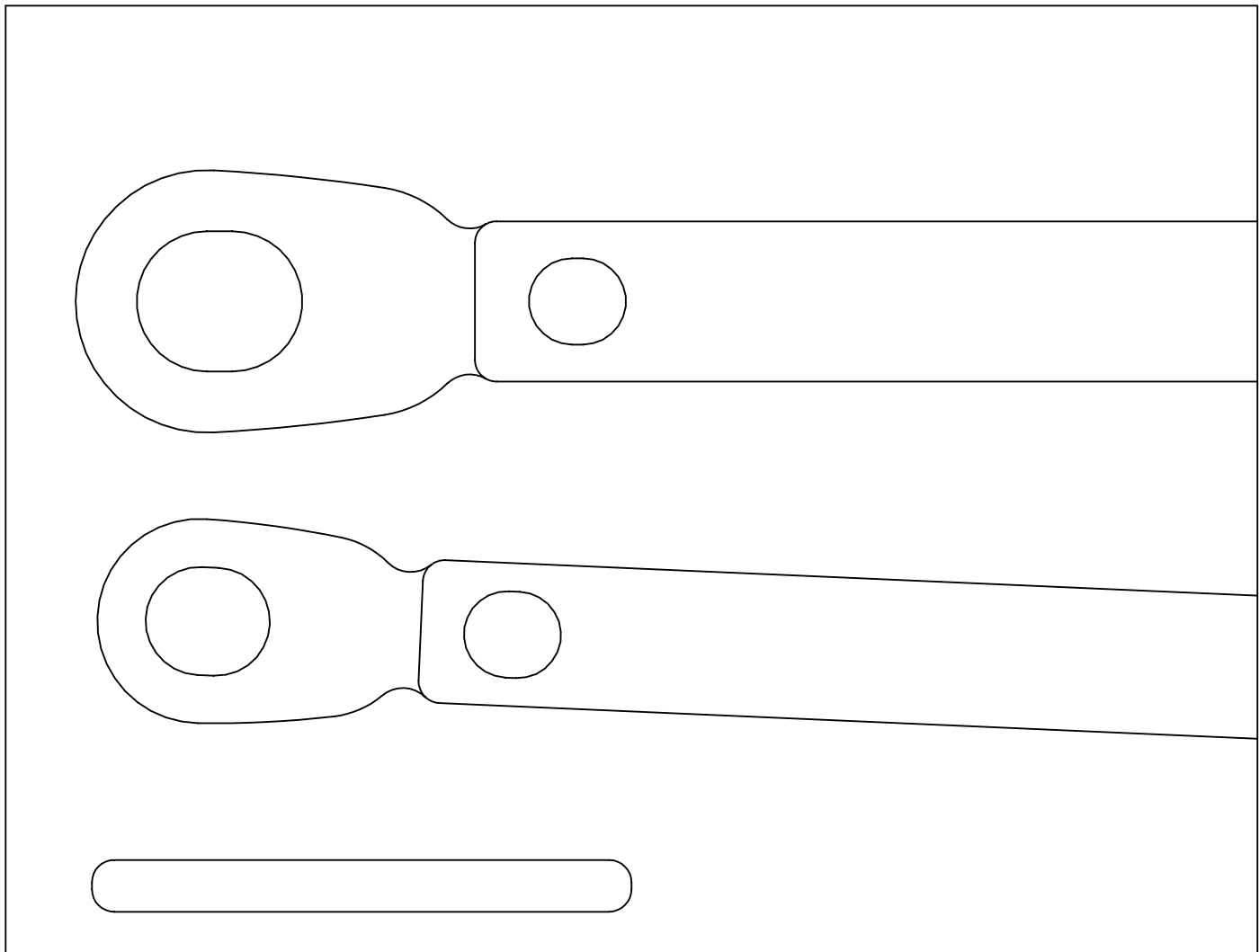

PART NUMBER

F-06427-T

PAGE (ROW-COLUMN)

1-1

Numbering starts
from the front
left corner.

DATE CREATED

31 MAR 2026

DATE REVISED

22 APR 2026

FoamFit Tools

Print on Letter at 100%

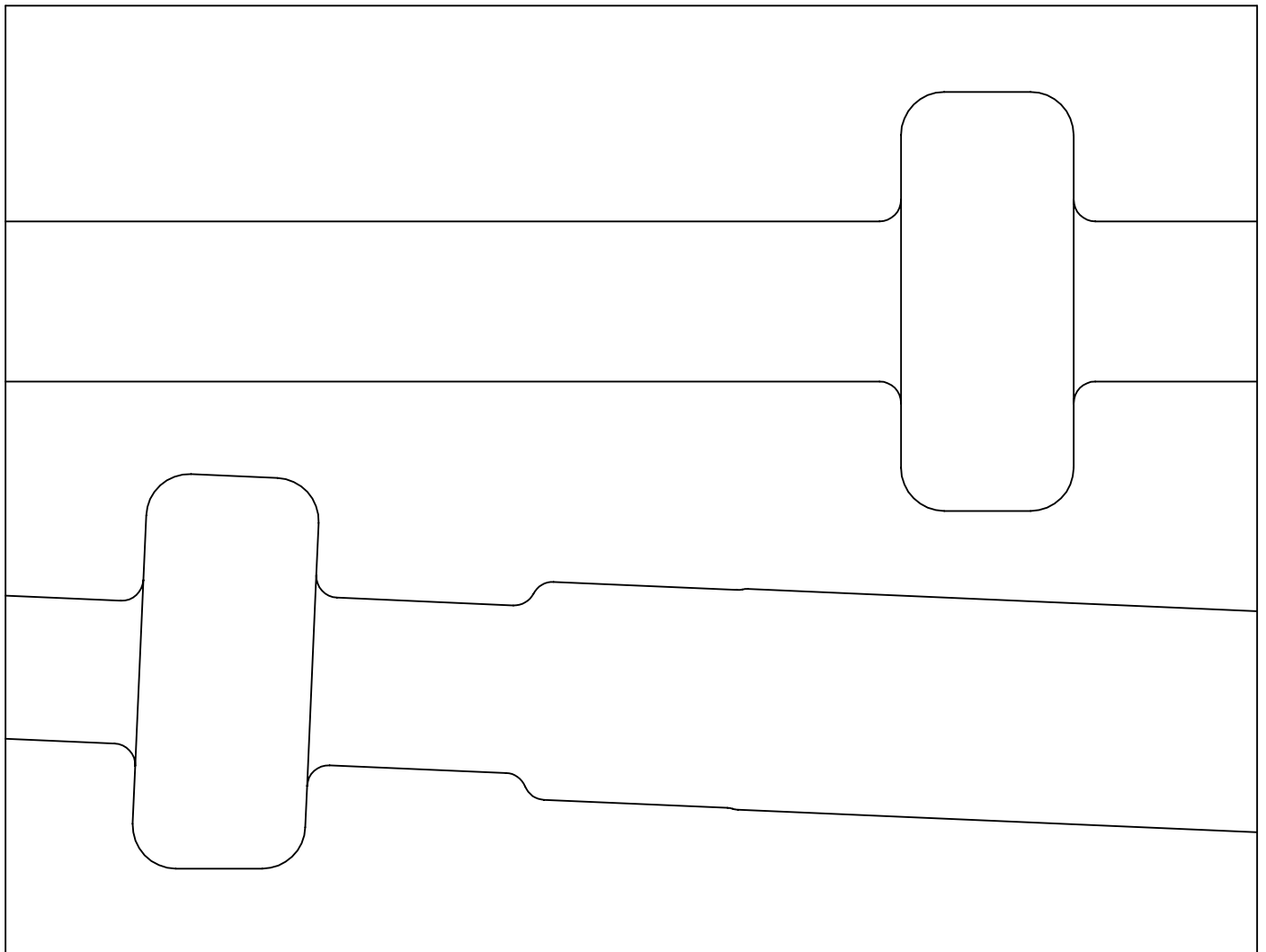

PART NUMBER

F-06427-T

PAGE (ROW-COLUMN)

1-2

Numbering starts
from the front
left corner.

DATE CREATED

31 MAR 2026

DATE REVISED

22 APR 2026

FoamFit Tools

Print on Letter at 100%

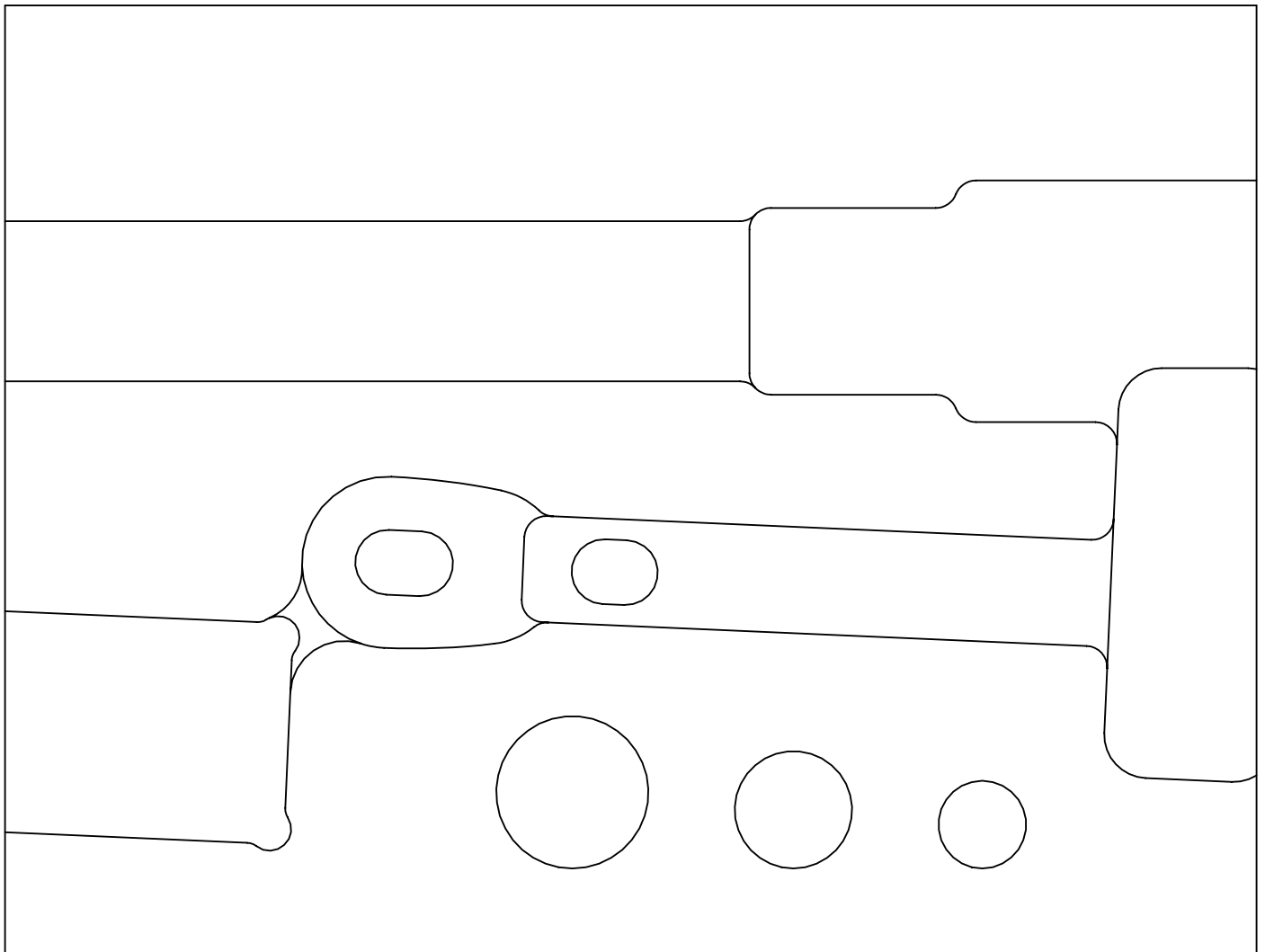

PART NUMBER

F-06427-T

PAGE (ROW-COLUMN)

1-3

Numbering starts
from the front
left corner.

DATE CREATED

31 MAR 2026

DATE REVISED

22 APR 2026

FoamFit Tools

Print on Letter at 100%

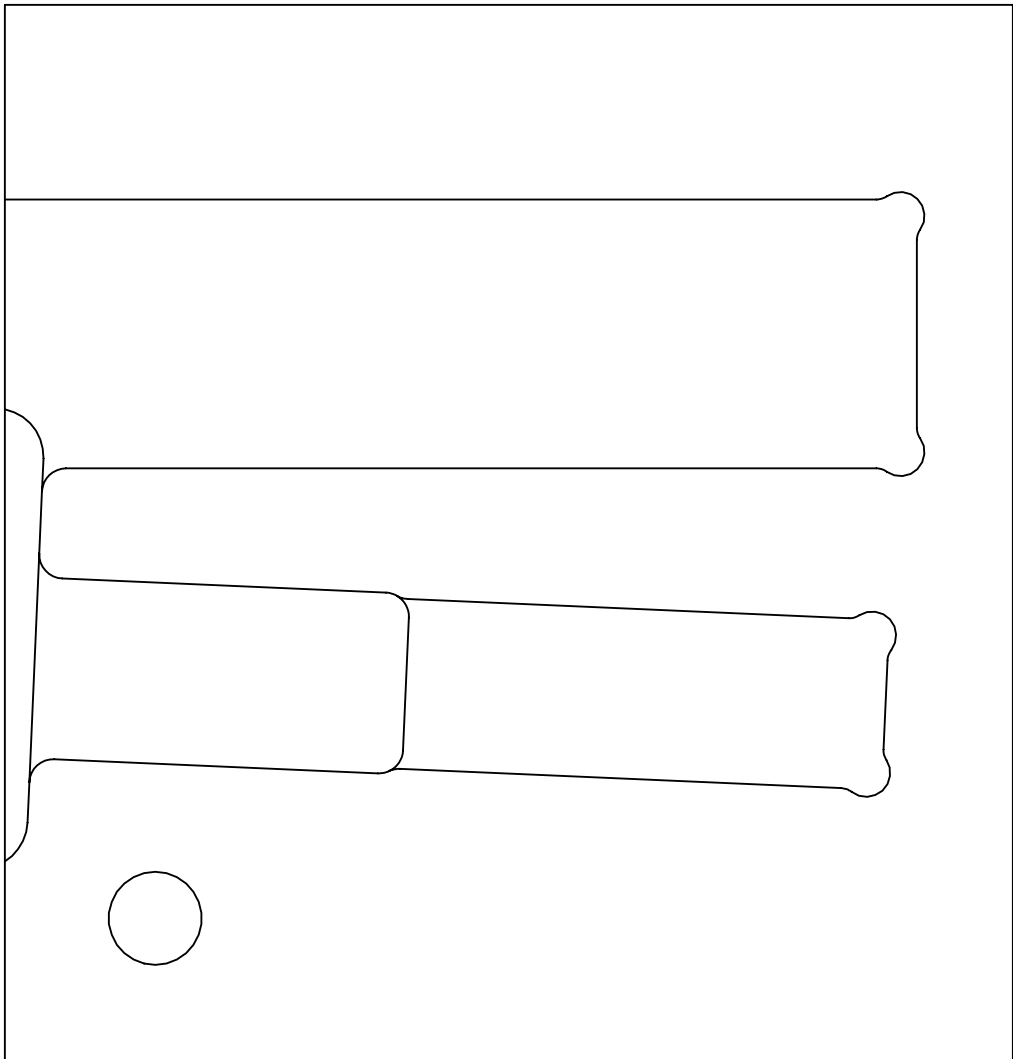

PART NUMBER

F-06427-T

PAGE (ROW-COLUMN)

1-4

Numbering starts
from the front
left corner.

DATE CREATED

31 MAR 2026

DATE REVISED

22 APR 2026

FoamFit Tools

Print on Letter at 100%